

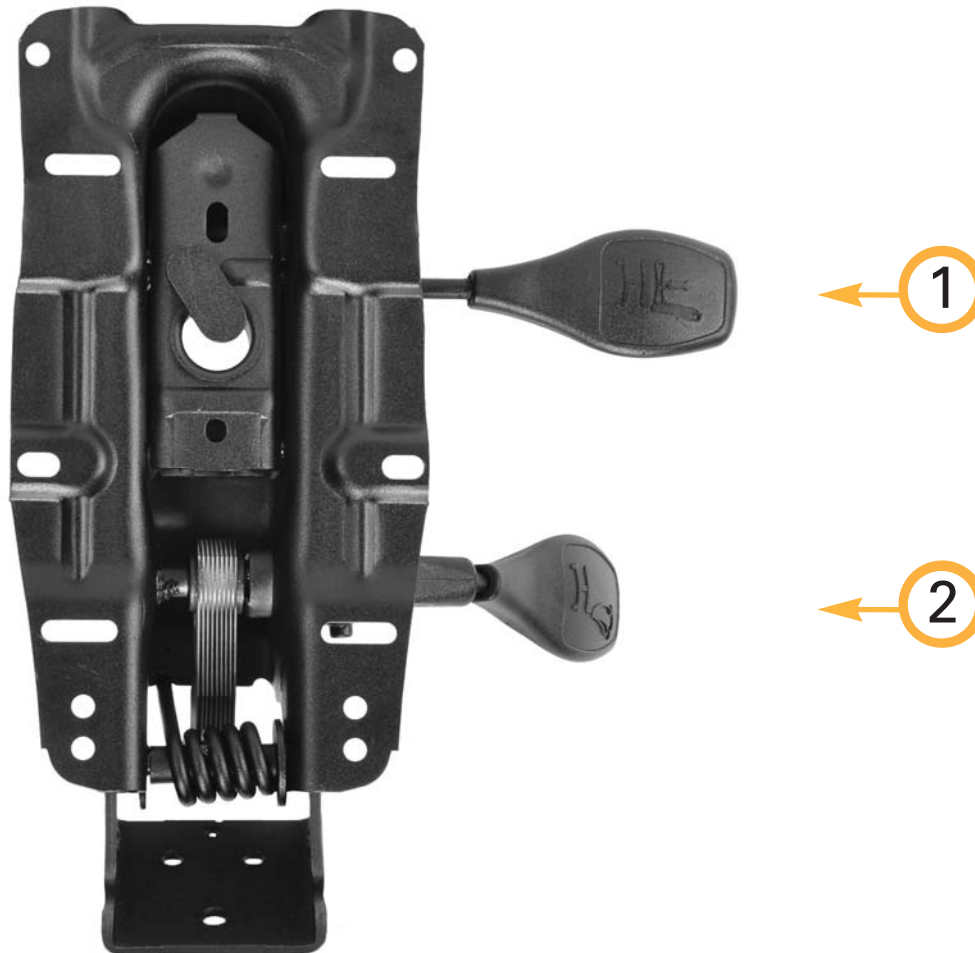

Seating Inc. | 60 N. State Street | PO Box 898 | Nunda, NY 14517 | 800.468.2475 | sales@seatinginc.com

Q22 Mechanism Instructions



- ① **Pneumatic Lift Adjustment:**
Lift lever towards seat to activate height adjustment.
- ② **Back Rest Angle Adjustment:**
Pull up on lever to make adjustment to back rest angle.
To lock the back rest in place, press the lever down

All adjustments are made while seated.



Q22 Assembly Instructions

Step 1

- ① Place Base and Caster Assembly (Figure A) on carpeted floor.
- ② Insert Pneumatic Cylinder (Figure B) Into Base (Figure A) by inserting tapered end (B1).
- ③ Place the seat assembly on the Pneumatic Cylinder (Figure B) by inserting the Pneumatic Cylinder Activator (B2) into the opening (C1) of the mechanism (*Figure C).
*Actual Q22 mechanism not shown, opening is similar.
- ④ Apply pressure for a secure fit.

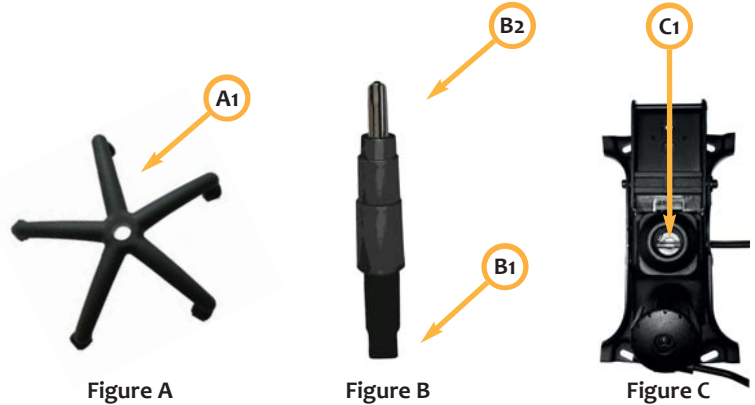

Step 2

- ⑤ At the completion of step 1, the bottom of the chair assembly should look like figure D.
- ⑥ Lay Seat Assembly on a carpeted floor as shown in Figure F.
- ⑦ Take Backrest (Figure E) and slide Backrest Bar (E1) into slot (F1) until the three holes line up for Allen head screws.
- ⑧ Hand tighten all three Allen head screws (Figure G) before tightening with Allen head key provided.

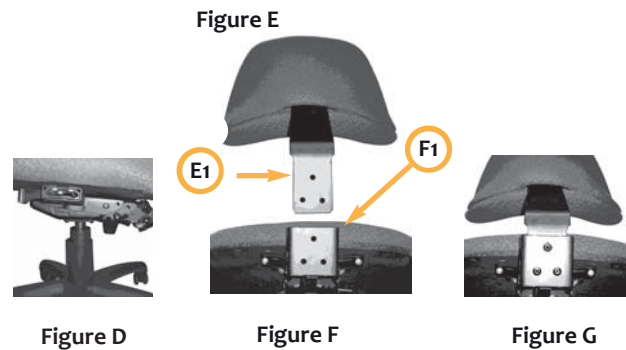

Ratchet Back - Lift back all the way up to release ratchet mechanism. Push back all the way down to activate. Lift back up slowly for 7 locking positions. Not available on Grid or Jay Series.